

Eccentric Plug Valve (Rotary Globe)

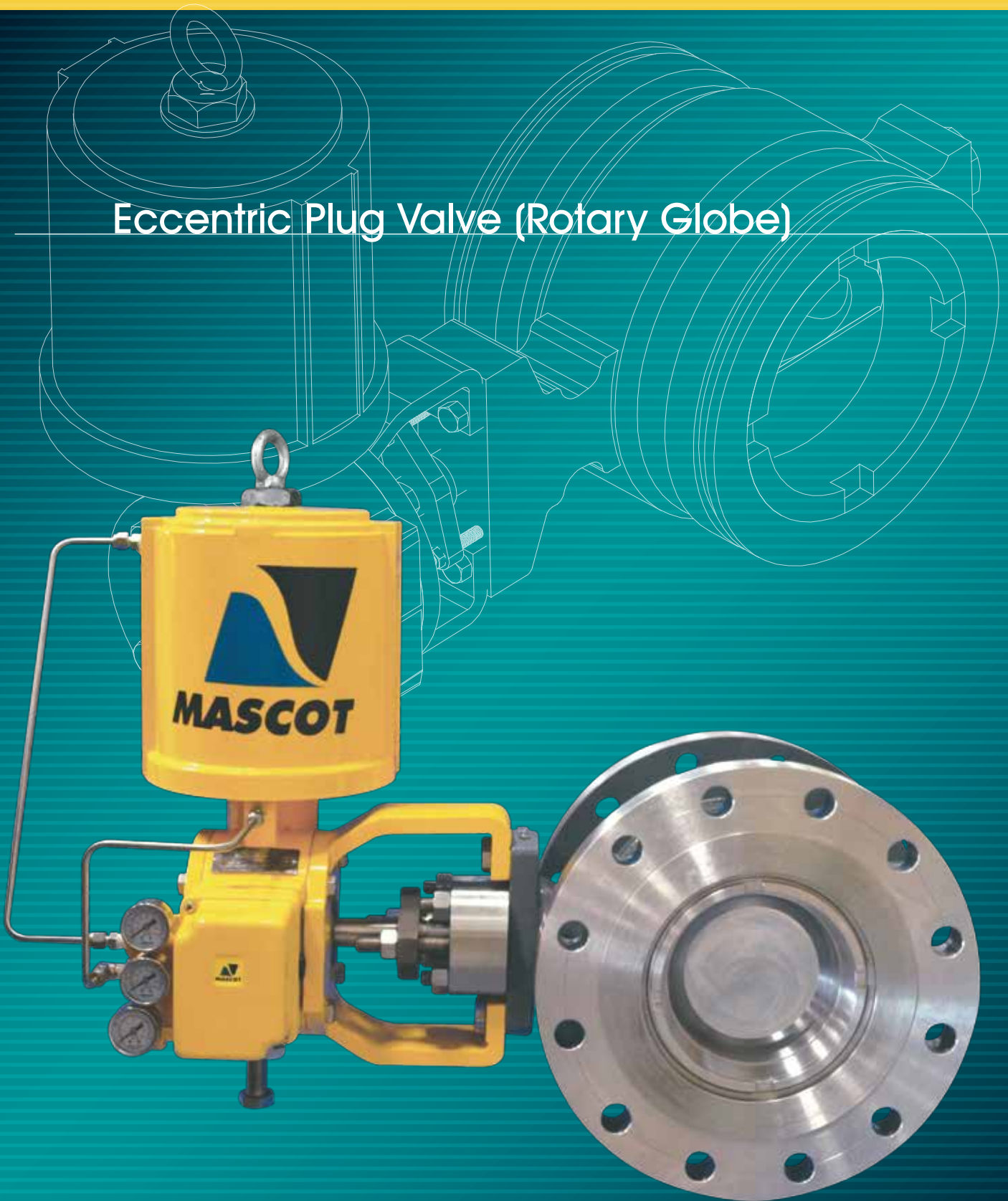

EFlo

High Rang-ability & Precision Control

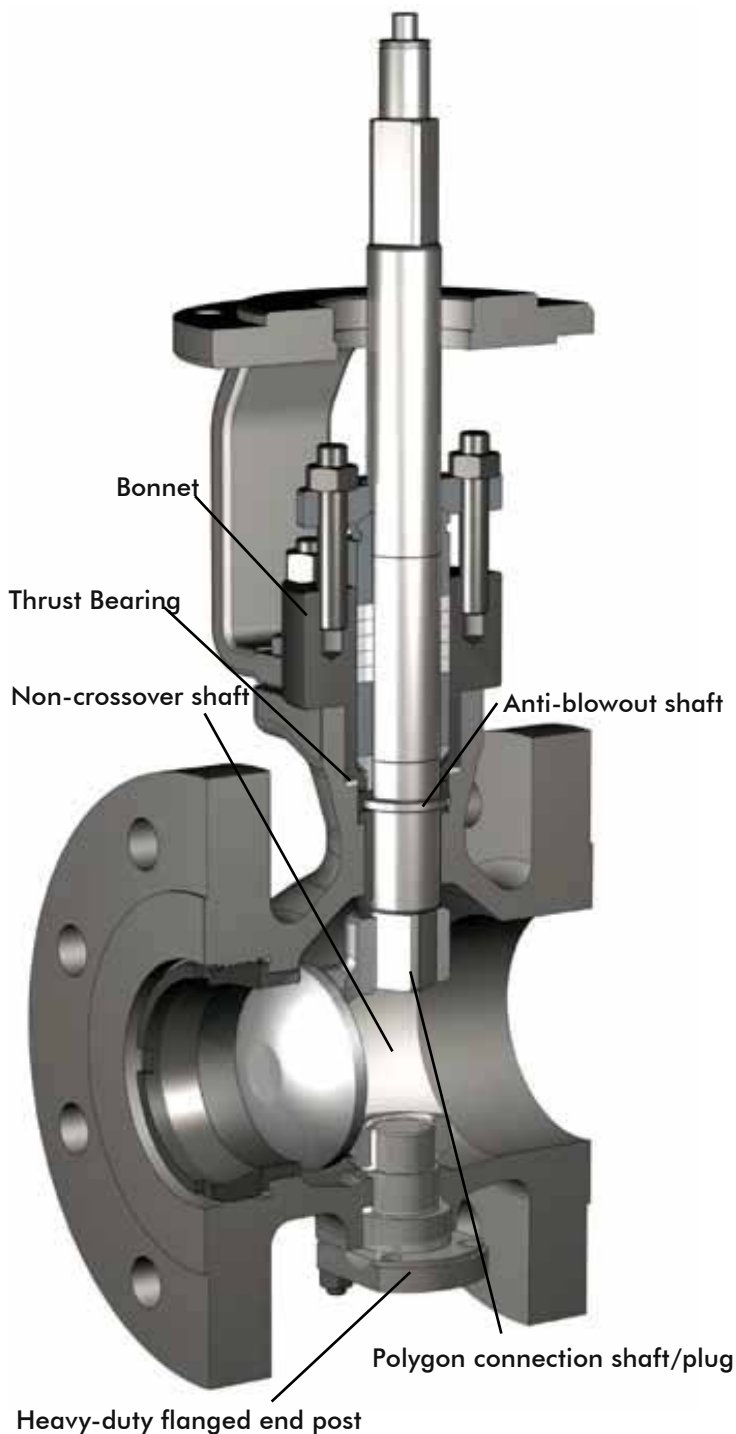

The EFlo offers a high range of precision control over extended life span through enhanced safety. The Mascot EFlo is a high performance, safety focused, economical, yet feature rich, Eccentric Rotary Plug control valve for applications demanding higher rangeability, precise control and higher flow capacity.

The EFlo valve offers rangeability up to 160:1 - compared to 50:1 for typical globe control valves and 20:1 for most butterfly valves.

A heavy-duty, non-crossover shaft is out of the valve's flow path. This superior design allows higher flow capacity for a given valve size. It also eliminates shaft damage from erosive process fluids. Many competitor designs use a straight-thru shaft which presents an obstruction to the flow, limiting capacity and presenting a target for erosion.

Because of its higher rangeability and increased flow capacity, the EFlo can be smaller in size and dimensional envelope for a given process condition, making it the most economical control valve for many general applications.

The EFlo offers positive, anti-blowout protection by means of a separate bonnet and integral shaft collar, as a standard option, emphasizing its status as the safest Eccentric Rotary Plug valve on the market.

The end-post shaft is designed so there is no possibility for it to be lost downstream. The end-post is rugged, precision machined, perfectly aligned, and positively retained so movement is smooth and precise. The oversized shaft provides improved reliability and valve life by eliminating shaft failures and reducing bearing wear.

Operated by a piston actuator coupled with a positioner, the EFlo maintains high positioning accuracy, repeatability, controlled high speed and reliable response.

EFlo

Features & Advantages

Features

Non-Crossover Shaft

Eccentric Rotary Plug

High rangeability

Separate Bonnet and Integral

Shaft Collar

Heavy-Duty End Post

Multiple Body Options

Trim Choices

Multiple packing options

Optional Noise Reduction Plate

Advantages

1. Unobstructed flow when fully open.

2. Up to 70% greater capacity than other ERP control valves.

3. Not eroded by process-borne particles.

4. Pocketless flow-path tolerates slurries, even up to 3% paper stock.

1. Plug does not rub seat ring. Less wear, less friction, more precision.

2. Stable throttling, low dynamic torque.

3. Stable throttling in either flow direction.

4. Inherently Linear characteristic. =% by positioner.

5. Flow direction assists movement to safety position on air-failure.

6. Robust, rigid seat and plug give increased durability.

7. Tight Shut-off, Class IV (Metal Seat), Class VI (Soft Seat), even after prolonged usage.

Rangeability > 160:1. The valve throttles repeatably all the way to shutoff.

A positive anti-blowout as a standard feature, in full compliance with ASME B16.34, ensures that the shaft cannot blow out, even if the actuator is removed.

Robust design for ultimate safety and reliability.

Flanged, Flangeless, and Globe Face-to-Face.

Full-area, 75/70%, 40%. Flow capacity can be closely matched to the application.

Economical and convenient when optimizing flow capacity or changing service conditions.

Configurations/materials available for most applications. Fugitive emission options also available.

Noise reduction of up to 15dB in compressible services

Table 1: Specifications

Sizes

1" through 24"

Pressure Classes

ASME Class 150, 300, 600

End Connections

Flanged and Flangeless (Sizes 1"-12")

Face-to-face

ANSI/ISA-75.08.02

ANSI/ISA Globe-75.08.01

Trim Area

100% & 40% all sizes, 70% through 6", 75% 8"-12".

Special sizes on application

Packing Options

PTFE V-ring, graphite ribbon, graphite braided.

Environmental packings

Characteristics

Characterized through positioner.

Operating Temperature

-148°F to 750°F (-100°C to 400°C)

Leakage Rates

ANSI/FCI 70-2 Class IV, ANSI/FCI 70-2 Class VI with soft seat

* For other specs/sizes contact factory

EFlo

Specifications

Materials of Construction (Standard)

Temperature Range	-20°F to +750°F (-29°C to +400°C)		-148°F to -29°F (-100°C to -20°C)
Body	CS (A216 WCB)	SS (A351 CF8M)	SS (A351 CF8M)
Plug	316 Stainless Steel		316L Stainless Steel with Stellite 6 overlay.
	316L Stainless Steel with Alloy 6 overlay.		
Shaft & End Post	17-4 PH		Nitronic 50 / Inconel 718
Bearings	316 SS, 440C, UNS S31803, Stellite		UNS S31803, Stellite
Bonnet	CS (A216 WCB)	SS (A351 CF8M)	A351 CF8M
Seat Retainer	Stainless steel (SS 316)		Stainless steel (SS 316)
Seat Ring	316 Stainless steel		316 Stainless steel
	316 w/ Alloy 6 overlay		316 w/ Alloy 6 overlay
	410/416 HT		
Soft Seat Insert	PTFE, PEEK for high temperature.		PTFE, PEEK for high temperature.
Packing Options	PTFE V-ring, Graphite Ribbon, Graphite Braided, Environmental or Fire-Safe packings.		
Packing Spacers & Stops	Stainless Steel		Stainless Steel
Gland Bolting	Stainless Steel		Stainless Steel
Gaskets	PTFE/Graphite		PTFE/Graphite

Note 1 : For NACE applications, some materials may change. Contact factory for details.

Note 2 : Special alloys are available on request for body and trim parts. Special alloys include, but are not limited to, Hestelloy C, Monel K500, 904L (Uranus B6), Duplex SS, and SS304L. For specific combinations of body and trim materials, consult factory.

Figure 2: Exploded View

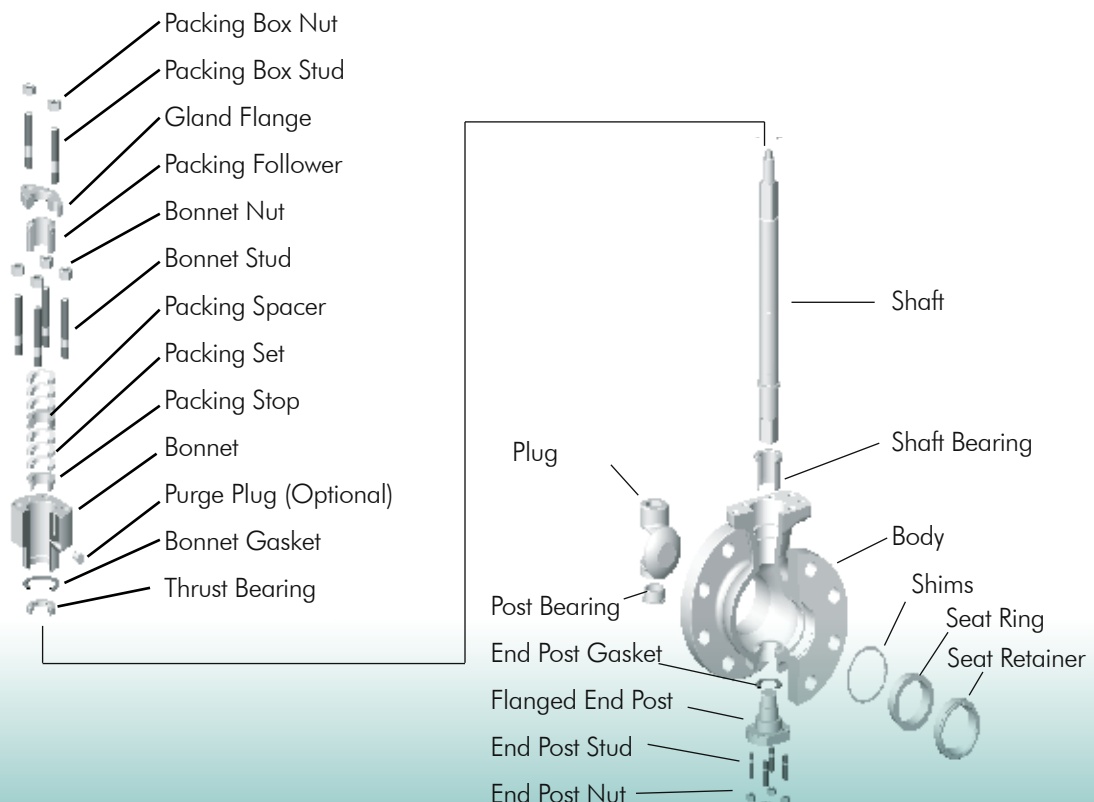

EFlo

Cv & Dimension Data

EFlo Face-to-face Options

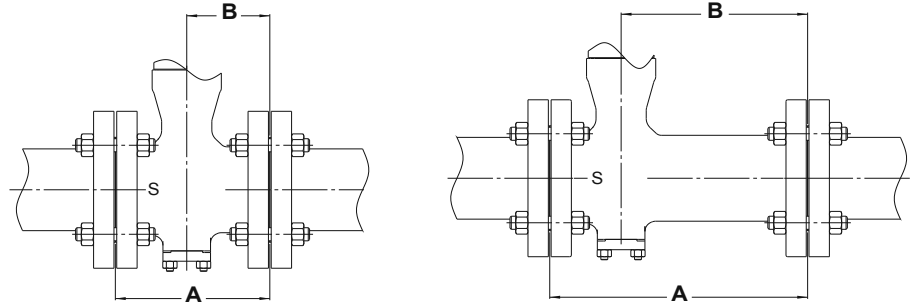

Cv (Flow Capacity) Tables

EFlo Cv at Full Travel (Inherent characteristic is linear)

Flow-to-Close (Shaft Up)		Actuator 90 degree travel (Shaft Down)			Actuator 90 degree travel (Shaft Up)		
Valve Size	Seat	Trim Size			Trim Size		
		40	70	100	40	70	100
1 (25)	Metal	7.1	13	18	8.4	15	21
	Soft Seat	6	7.1	10	6	8.4	12
1.5 (40)	Metal	19	33	47	20	35	50
	Soft Seat	19	33	39	20	35	42
2 (50)	Metal	32	52	80	24	43	78
	Soft Seat	32	52	71	24	43	69
3 (80)	Metal	104	182	241	95	167	214
	Soft Seat	104	182	241	95	167	214
4 (100)	Metal	170	267	405	150	220	302
	Soft Seat	170	267	405	150	220	302
6 (150)	Metal	382	669	955	324	567	730
	Soft Seat	382	669	955	324	567	730
8 (200)	Metal	-	1275	1700	-	847	1130
	Soft Seat	-	1275	1700	-	847	1130
10 (250)	Metal	-	1879	2505	-	1339	1785
	Soft Seat	-	1879	2505	-	1339	1785
12(300)	Metal	-	2700	3600	-	1920	2560
	Soft Seat	-	2700	3600	-	1920	2560

Dimensions and Weights

EFlo Face-to-face Dimensions

Valve Size (in./mm)	ANSI/ISA-75.08.02				ANSI/ISA-75.08.01, Class 150				ANSI/ISA-75.08.01 Class 300			
	A		B		A		B		A		B	
	in.	mm	in.	mm	in.	mm	in.	mm	in.	mm	in.	mm
1/25	4.02	102	2.01	51	7.25	184	4.76	121	7.75	197	5.16	131
1.5/40	4.49	114	2.24	57	8.75	222	5.83	148	9.25	235	6.22	158
2/50	4.88	124	2.44	62	10.00	254	6.89	175	10.50	267	7.28	185
3/80	6.50	165	3.25	83	11.75	298	7.48	190	12.50	318	8.11	206
4/100	7.64	194	3.82	97	13.88	353	9.17	233	14.50	368	9.49	241
6/150	9.02	229	4.65	118	17.75	451	11.57	294	18.62	473	12.01	305
8/200	9.57	243	5.35	136	21.38	543	15.28	388	22.38	568	15.75	400
10/250	11.69	297	6.22	158	26.50	673	19.88	505	27.88	708	20.55	522
12/300	13.31	338	6.77	172	29.00	737	21.57	548	30.50	775	22.32	567

Shipping Weights for Body Sub-Assembly (Weights for all class ratings)

S. No	Size	ISA 75.08.01 FF				ISA 75.08.02 FF											
		Flanged				Flanged						Flangeless					
		CL 150		CL 300		CL 150		CL 300		CL 600		CL 150		CL 300		CL 600	
		Kg	Lbs	Kg	Lbs	Kg	Lbs	Kg	Lbs	Kg	Lbs	Kg	Lbs	Kg	Lbs	Kg	Lbs
1	1"	6	14	8	17	5	12	6	14	7	16	5	10	5	10	5	10
2	1.50"	9	19	11	24	7	16	10	21	11	24	6	13	6	14	6	13
3	2"	11	24	12	27	9	19	11	23	12	27	7	15	8	17	9	21
4	3"	20	45	24	53	17	38	21	45	23	51	12	27	15	33	19	41
5	4"	24	53	32	71	19	42	26	58	37	82	14	31	17	37	24	54
6	6"	48	106	65	142	36	79	50	110	74	163	28	62	39	86	50	110
7	8"	70	155	92	204	52	115	71	157	109	240	37	82	52	115	68	151
8	10"	136	300	172	380	105	231	134	295	206	454	86	191	107	235	139	306
9	12"	195	429	243	537	151	333	187	411	252	555	119	262	142	314	177	389

EFlo

EFlo Mounting Orientations - Air to Close

EFlo Mounting Orientations - Cylinder Actuator

AIR-TO-CLOSE, FAIL OPEN CONFIGURATION			
Flow-to-Open (Shaft Downstream)		Flow-to-Close (Shaft Upstream)	
HORIZONTAL FLOW			LEFT HAND PIPE MOUNTING
			RIGHT HAND PIPE MOUNTING
VERTICAL FLOW			FLOW DOWN
			FLOW UP

EFlo

EFlo Mounting Orientations - Air to Open

EFlo Mounting Orientations - Cylinder Actuator

AIR-TO-OPEN, FAIL CLOSE CONFIGURATION			
	Flow-to-Open (Shaft Downstream)	Flow-to-Close (Shaft Upstream)	
HORIZONTAL FLOW			LEFT HAND PIPE MOUNTING
			RIGHT HAND PIPE MOUNTING
VERTICAL FLOW			FLOW DOWN
			FLOW UP

EFlo

Dimensions and Weights (continued)

Cylinder Actuator Specifications

Type	Double-acting, cylinder with fail-safe spring action
Sizes	25, 50, 100, 200
Action	Air-to-open, Air-to-close, Fail-in-place
Supply Pressure	150 psig/10.3 barg* (maximum)
Auxiliary	Declutchable side-mounted; manual gear operated; handlever
Stroke	90°
Springs	Standard, extended (sizes 25 & 50), dual sizes (100 & 200)

Cylinder Actuator Shipping Weights

Model	Kg	Lbs
25	16	35
50	33	73
100	73	161
200	120	265

* Some restrictions may apply to certain applications

Valve Size / Cylinder Actuator Compatibility

Actuator Size (in ²)	Spring Type	Valve Size (in)									Weights	
		1	1.5	2	3	4	6	8	10	12	Kg	Lbs
25	STD	X	X	X	X	X					16	35
25	EXTD	X	X	X	X	X						
50	STD				X	X	X	X	X		33	73
50	EXTD				X	X	X	X	X			
100	STD						X	X	X		73	161
100	DUAL						X	X	X	X		
200	STD						X	X	X	X	120	265
200	DUAL						X	X	X	X		

EFlo Spring Cylinder Actuator

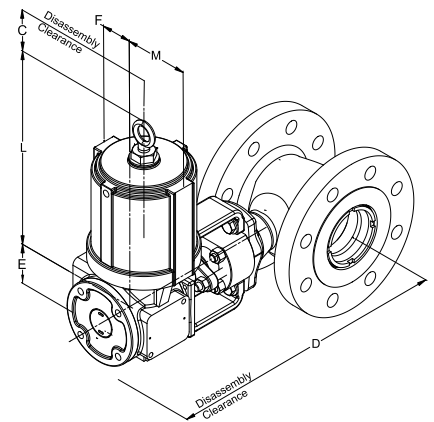

EFlo Dimensions (Spring Cylinder Actuator)

Valve Size (in./mm)	Actuator Size	Shaft Size		C		D		E		F		L		M	
		in.	mm	in.	mm	in.	mm	in.	mm	in.	mm	in.	mm	in.	mm
1/25	25	0.4	11	6.0	152	20.0	510	5.6	142	2.2	56	13.1	332	4.3	109
1.5/40	25	0.6	16	6.0	152	21.0	535	5.6	142	2.2	56	13.1	332	4.3	109
2/50	25	0.6	16	6.0	152	21.0	535	5.6	142	2.2	56	13.1	332	4.3	109
2/50	50	0.6	16	8.0	203	21.0	535	6.7	170	2.5	64	18.0	457	6.6	168
3/80	25	0.9	23	6.0	152	25.0	635	5.6	142	2.2	56	13.1	332	4.3	109
3/80	50	0.9	23	8.0	203	25.0	635	6.7	170	2.5	64	18.0	457	6.6	168
4/100	25	0.9	23	6.0	152	26.0	661	5.6	142	3.9	99	13.1	332	8.7	221
4/100	50	0.9	23	8.0	203	26.0	661	6.7	170	2.5	64	18.0	457	6.6	168
6/150	50	1.0	26	8.0	203	27.0	680	6.7	170	2.5	64	18.0	457	6.6	168
6/150	100	1.5	38	11.0	279	29.0	722	9.1	231	3.9	99	22.6	574	8.7	221
8/200	50	1.0	26	8.0	203	27.0	685	6.7	170	2.5	64	18.0	457	6.6	168
8/200	100	1.5	38	11.0	279	29.0	733	9.1	231	3.9	99	22.6	574	8.7	221
10/250	50	1.0	26	8.0	203	30.0	751	6.7	170	2.5	64	18.0	457	6.6	168
10/250	100	1.5	38	11.0	279	32.0	802	9.1	231	3.9	99	22.6	576	8.7	221
12/300	100	1.5	38	11.0	279	33.0	827	9.1	231	3.9	99	22.6	576	8.7	221

For face-to-face dimensions, see Table on Page 5.

All dimensions are to be used for estimation only. Certified drawings will be supplied up request.



MASCOT VALVES PVT. LTD.

166 / 167, G I D C, Naroda, Ahmedabad : 382330. India
 Phone : +91 79 22821619/22823369, Fax : +91 79 22822430
 Email : info@mascotvalves.com / web : www.mascotvalves.com