

FLOATING MISALIGNMENT UNIONS ALLOW PROCESS CONNECTION CENTERLINES TO VARY +/- 1/4"



K9900 Bulk Tank Gauge w/ Threaded Connections

K9957 Bulk Tank Gauge w/ Integral Valve on Bottom and Threaded Connection on Top

K9957 Bulk Tank Gauge w/ Optional Flange Connection

The patented K9900 Series Level Gauge features an innovative casting design which will simplify the installation process and eliminate other typical problems associated with gauge glasses. The K9900 incorporates floating misalignment unions, which will allow process connection centerlines to vary +/- 1/4". The gauge also has integral offset pattern valves with ball check shutoffs. 1/2" FNPT vent and drain connections are inline for routine sight glass maintenance. The K9900 Series Level Gauge delivers a safe, low maintenance, cost effective solution to common sight glass applications.

APPLICATIONS:

- Low to Medium pressure applications up to 500 psi
- Bulk storage tanks
- Marine
- Low pressure scrubbers and surge tanks
- Seal pots

PRODUCT FEATURES:

- Floating misalignment unions allow process connection centerlines to vary +/- 1/4"
- Offset pattern valves with ball check shutoffs
- Ball check shutoff valves protect tank inventory
- Tubular sight glass allows for easy viewing of liquid level
- Innovative casting design includes all necessary mounting components up to process connection
- Rugged armored gauge construction protects sight glass from mechanical impact
- 1/2" FNPT vent and drain ports for routine gauge glass maintenance
- Additional 1/4" FNPT side ports for optional mounting of other instrumentation for level gauge monitoring
- Custom scales for tank volume or other calibrations are available upon request (Refer to Page 12)
- Armored frame and polycarbonate shield protect operator in case of accident
- K9900 is ABS certified for marine applications
- Minimum loss of visual indication

K9900 BULK TANK GAUGE

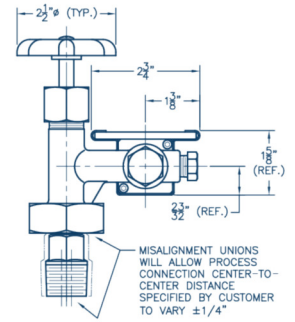
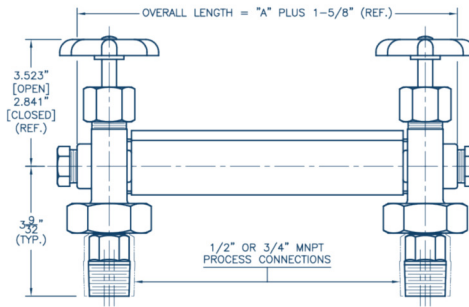
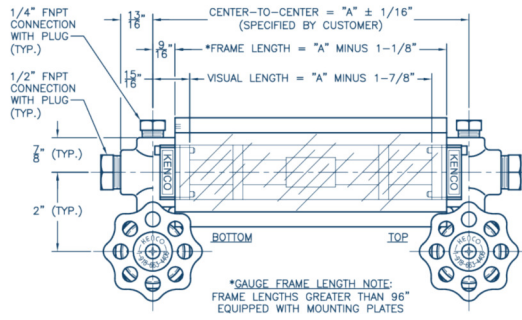

K9957 BULK TANK GAUGE

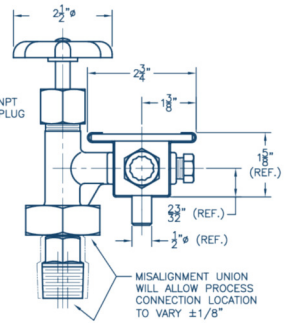
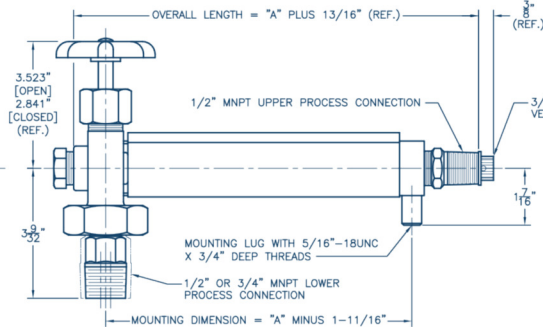
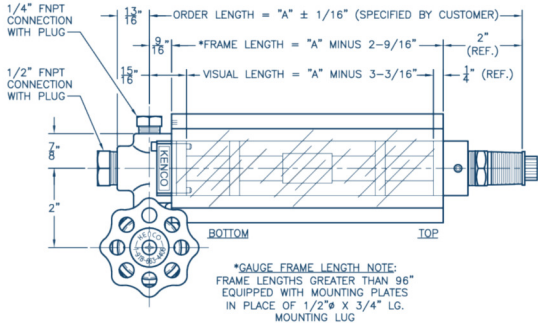

ORDERING GUIDE

K9900 Series Bulk Tank Gauge

REQUESTED BY: _____ COMPANY: _____

ADDRESS: _____ CITY: _____ STATE: _____ ZIP: _____

PHONE: _____ FAX: _____ EMAIL: _____

--	--	--	--	--

Gauge Style

K99 = Gauge w/ Top & Bottom Integral Valves
 K9957 = Gauge w/ Integral Valve on Bottom and 1/2" MNPT x 3/8" FNPT Connection on Top

Process Connection(s)

M50=1/2" MNPT
 M75=3/4" MNPT
 FL50=1/2" 150# R.F. Flange
 FL75=3/4" 150# R.F. Flange
 FL10=1" 150# R.F. Flange
 FL15=1-1/2" 150# R.F. Flange
 FL20=2" 150# R.F. Flange
 (Other Flange Sizes/Ratings Available upon Request)

K99: Center-to-Center Dimension (inches)

K9957: Lower Connection Centerline to Top of Gauge (inches)

Material of Construction

C=Zinc Plated Carbon Steel
 A=Stainless Steel
 S6=All 316 Stainless Steel

Seal Material

V=Fluorocarbon
 A=Aflas
 B=Buna-N
 T=FEP Encapsulated Silicone
 E=Ethylene Propylene
 (Other Materials Available upon Request)

--	--	--	--	--

Shield Options*

L=Clear Polycarbonate
 H=Height Scale
 RH=Rate Height Scale
 MH=Metric Height Scale
 MRH=Metric Rate Height Scale
 M=Expanded Metal Guard

Sight Tube Options**

GS=5/8" O.D. Glass
 RL=5/8" O.D. Redline Glass
 (Other Materials Available upon Request)

Maximum Working Pressure (PSIG)

Maximum Operating Temperature (°F)

Steam

S=Steam Application
 NS=Non-Steam Application

• Example Order Number: K99FL10-35-AEL-RL-210-160-NS

* See page 12 for shield descriptions.

** Based on application data provided, KENCO will select the appropriate sight tube material, i.e. high pressure glass.