



ALCM-UT

Coriolis Mass Flowmeter

Model ALCM Series

GENERAL

SMARTMEASUREMENT's ALCM-UT uses two tubes formed into a U-shaped geometry in a parallel arrangement which are vibrated at their resonant frequency by coils. Any mass flow passing through the tubes will generate Coriolis forces, which appear whenever a mass moves radially in a rotating system. These forces have opposite effects on the inlet and outlet side, deforming each tube by a minor amount. The excursion of the pipes is detected by sensors located at the meter inlet and outlet and is measured as a time delay, or phase shift. The phase shift between the inlet and outlet of both tubes is directly proportional to the mass flow rate. The resonant frequency of the tubes changes in proportion to the density of the fluid media. This effect allows for the measurement of media density. Using only one sensor, both density and temperature measurements may be performed as the extent of deformation of the pipes is temperature- dependent. Therefore, the temperature is measured for compensation purposes. Using only one instrument, values including mass flow, density, and temperature may be measured. The ALCM's microprocessor-based circuitry also allows for calculated values such as volumetric flow, % concentration, and % water-cut to be determined.



FEATURES

- Suitable for aggressive and contaminated media
- Measurement of mass flow, density, temperature and volume flow
- Measurement & display of % water cut for oil/water mixtures
- High rotation frequency and well-balanced measuring tubes
- Excellent purging and sterilization qualities due to a construction free of dead spots
- Operation up to +250°C
- Individual 8-point-calibration including report
- EX protection (optional)
- PT100 temperature sensor Included

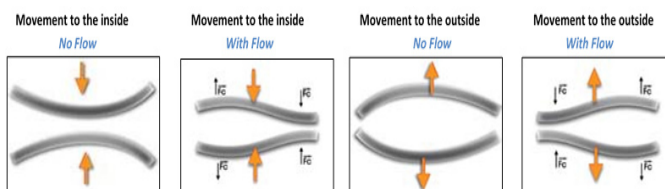

SPECIFICATIONS

- | | | | |
|--------------------------|---|-------------------------|---|
| • Flow Range: | 2,866~5.5 million Lb/hr
(1,300~1.5 million kg/hr) ** | • Ambient Temperature: | -5~131°F (-20~55°C) |
| • Line Sizes: | 1½"~12" (40-300 mm)** | • Max Working Pressure: | 360 psig (2.5MPa) std,
930 psig optional |
| • Process Connections: | Flanged (ANSI, DIN, Tri-Clamp®) | • Measuring Tube Mat'l: | SS per DIN1.4571
(AISI 316Ti) standard |
| • Tube geometry: | U-Tube | • Housing Material: | SS #304 |
| • Accuracy: | ±0.5% of reading (std), 0.2% or 0.15% (opt) | • Power Supply: | 24 V _{DC} , ± 20%; 86~260V _{AC} , 50~60Hz |
| • Repeatability: | ±0.075% of reading | • Power Consumption: | Less than 6W |
| • Frequency: | 10-2000 Hz | • Outputs: | 4-20 mA, 0-10 kHz pulse, RS485 |
| • Display: | Color Graphic OLED | • Density Meas. Range: | 0.2~2.0 g/cc |
| Eng. Units (mass): | kg, lb, ton | • Density Accuracy: | ±0.001 g/cc |
| Eng. Units (Temp): | °C, °F | • Water Cut Meas.Range: | 0-100% |
| Eng. Units (Vol.): | m ³ , Liter, US Gallon, Imperial Gallon, Mil-
lion Gallon | • Water Cut Accuracy: | ±0.1% of range |
| • Zero Stability: | 0.1% full-scale | • Temperature Accuracy: | up to ±1°C |
| • Zero Drift (%FS / °C): | 0.005 | • Approvals: | UL/CUL/CSA, Class 1, Div I & II  |
| • Process Temperature: | -58~482°F (-50~250°C) | | |

**12", DN300 Available, Please contact factory

METER SIZE INCHES (MM)	FLOW RANGE LB/HR (KG/HR) (0.2% & 0.5% ACCURACY)	FLOW RANGE LB/HR (KG/HR) (0.15% ACCURACY)	STABILITY OF ZERO POINT LB./HR. (KG/HR.)
1½" (40)	2,866~70,547 (1,300~32,000)	4,409~70,547 (2,000~32,000)	2.64 (1.2)
2" (50)	4,409~110,231 (2,000~50,000)	7,716~110,231 (3,500~50,000)	4.4 (2)
3" (80)	13,227~308,647 (6,000~140,000)	17,636~308,647 (8,000~140,000)	13.22 (6)
4" (100)	22,046~440,924 (10,000~200,000)	33,069~440,924 (15,000~200,000)	17.63 (8)
6" (150)	55,115~1,102,311 (25,000~500,000)	77,161~1,102,311 (35,000~500,000)	44.09 (20)
8" (200)	110,231~2,204,622 (50,000~1,000,000)	220,462~2,204,622 (100,000~1,000,000)	88.18 (40)
10" (250)	154,323~3,306,933 (70,000~1,500,000)	220,462~3,306,933 (100,000~1,500,000)	132.27 (60)
12" (300)	264,554~5,511,556 (120,000~2,500,000)	374,785~5,511,556 (170,000~2,500,000)	220.46 (100)

Accuracy:

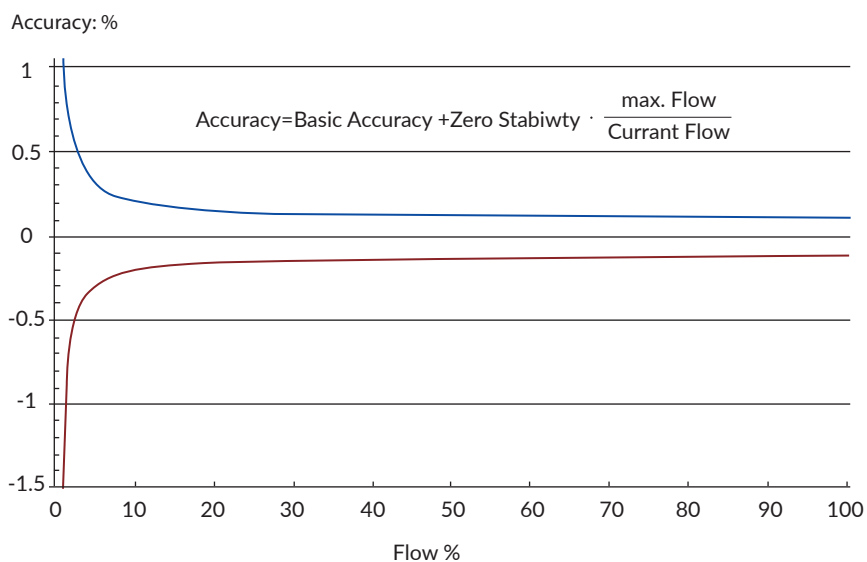

This diagram shows typical values. Individual values may be taken from the calibration records supplied with each meter.

Repeatability:

ACCURACY	0.10%	0.20%	0.50%
REPEATABILITY	±0.05%	±0.1%	±0.25%

Accuracy is calculated based on the water measurement under the condition of +20°C ~ 25°C and 0.1MPa ~ 0.2MPa.

Density Measuring:

DENSITY RANGE	(0.2~2.0) g/cm ³
BASIC ERROR	±0.002g/cm ³ (Affected by the transducer)
REPEATABILITY	0.001g/cm ³

DIMENSIONS

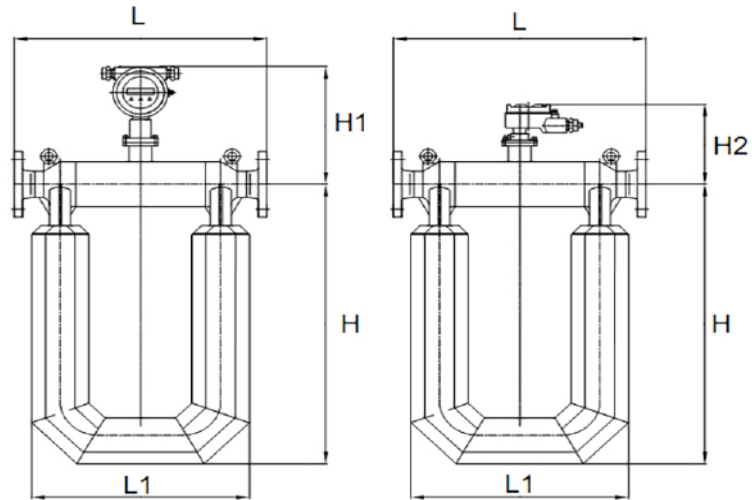

-All dimensions in units of inches (mm)-

NOMINAL LINE SIZE	L INCHES (MM)	L1 INCHES (MM)	H INCHES (MM)	H1 INCHES (MM)	H2 INCHES (MM)	WEIGHTS LB (KG)
1½" (40 mm)	20.47 (520)	18.50 (470)	25.98 (660)	11.02 (280)	8.26 (210)	66.1 (30)
2" (50 mm)	21.96 (558)	21.65 (550)	27.95 (710)	11.41 (290)	8.66 (220)	88.2 (40)
3" (80 mm)	30.70 (780)	27.95 (710)	40.94 (1040)	12.59 (320)	9.84 (250)	220.5 (100)
4" (100 mm)	36.22 (920)	33.85 (860)	44.88 (1140)	13.78 (350)	11.02 (280)	418.8 (190)
6" (150 mm)	43.30 (1100)	41.34 (1050)	59.84 (1520)	14.96 (380)	12.20 (310)	716.5 (325)
8" (200 mm)	53.70 (1364)	45.67 (1160)	65.16 (1655)	16.54 (420)	13.78 (350)	1181.7 (536)
10" (250 mm)	81.49 (2070)	50 (1270)	124 (3150)	20.47 (520)	17.71 (450)	3357.6 (1523)
12" (300 mm)	CONTACT FACTORY FOR FURTHER INFORMATION					

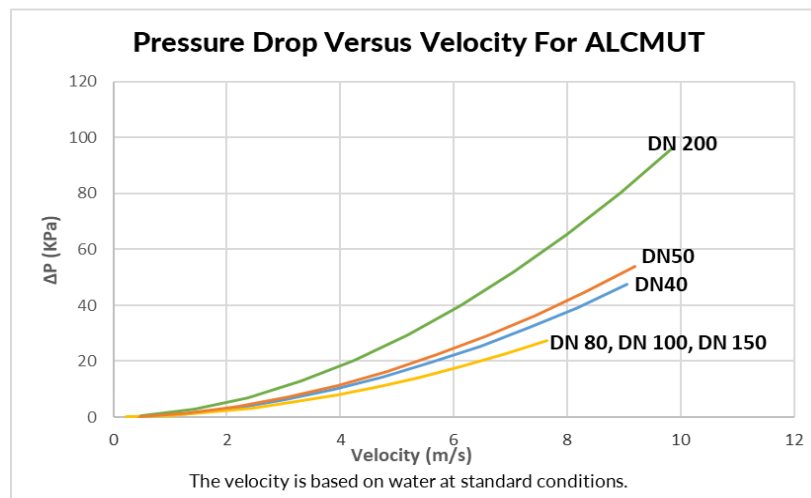

TYPE OF FLUID	Please provide the name of your fluid, including operating density and viscosity
FULL-SCALE FLOW RATE	Please provide the max and min flow rate, normal flow rate also
LINE SIZE	Please provide the line size and connection
PROCESS PRESSURE & TEMPERATURE	We will calibrate your flow meter as close to your operating conditions as possible
PRESSURE DROP	Please indicate the maximum allowable pressure drop
TYPE OF ELECTRONICS	Please specify output and installation type (wall mount, panel mount, etc.)
POWER REQUIREMENTS	Please specify AC or DC power supply

ALCM-UT SERIES

EXAMPLE 1: ALCM-UT-25F-5-1-1-CYS-NX-DC-NN

ALCM-UT	**	**	**	**	**	**	**	**	**	DESCRIPTION	
1½" (40 mm) 2,866~70,547 Lb/hr (1,300~32,000kg/hr)	40									Nominal Line Size	
2" (50 mm) 4,409~110,231 Lb/hr (2,500 - 50,000 kg/hr)	50										
3" (80 mm) 13,227~308,647 Lb/hr (6,000 - 140,000 kg/hr)	80										
4" (100 mm) 22,046~440,924 Lb/hr (10k- 200k kg/hr)	100										
6" (150 mm) 55,116~1,102,311 Lb/hr (25K~500k kg/hr)	150										
8" (200 mm) 110,231~2,204,623 Lb/hr (50K-1000k kg/hr)	200										
10" (250 mm) 154,323~3,306,933 Lb/hr (70K-1.5 million kg/hr)	250										
12" (300 mm) 264,554~5,511,556 Lb/hr (120K-2.5 million kg/hr)	300										
150# ANSI Flange	F									Process Connections	
300# ANSI Flange	F3										
Other	O										
0.1%		1								Accuracy	
0.2%		2									
0.5%		5									
-58 to 257°F (-50 to 125°C) max - Standard		1								Temperature Rating	
-58 to 392°F (-50 to 200°C) - Remote display only		2									
-58 to 482°F (-50 to 250°C) - Remote display only		3									
232 psig (1.6 MPa) - Standard			1							Pressure Rating	
362 psig (2.5 MPa)			2								
580 psig (4.0 MPa)			3								
928 psig (6.4 MPa)			4								
TSY Compact Version - surface touch control, display, 4-20mA, RS485							CYS			Transmitter	
TSY Compact Version - surface touch control, display, 4-20mA, RS485, HART							CYH				
TSY Remote Version - surface touch control, display, 4-20mA, RS485							RYS				
TSY Remote Version - surface touch control, display, 4-20mA, RS485, HART							RYH				
Non-Explosion								NX		Approval	
Exdib II CT~3T6 for transducers, Exd[ib] II CT6 transmitter (for remote)								XI			
Exdib II CT4~T6 (for compact)								XD			
85-260 V _{AC} , 50/60Hz									AC	Power Supply	
24 V _{DC}									DC		
Standard SS #316L measuring tube										NN	Options
Extra signal cable for remote type transmitters (per meter length)										CAB	
Heat jacket										HJ	
Special pressure or temperature applications - contact factory										**	

